



RANGE

Delivery size : up to 150 mm

Capacity : up to 550 m³/hr

Head : up to 100 metres

Temperature : -10°C to 100°C.

APPLICATION

Power plant, Fire Fighting, Mining Industries, Petrochemical Industries Chemical Industries, Water Treatment Plant, Pharmaceutical Plant, Mine water, Lift irrigation, Sprinkler systems, Fire fighting, Booster services, Pumping brines, Oils etc.

FEATURES

These are single stage, single suction, horizontal shaft type. They are made in accordance with DIN 24255. Models are available to operate at 1450 rpm and 2900 rpm at 50 Hz

Casing :

End suction, volute type with top centre line discharge. Suction and discharge nozzles as well as the supporting feet are cast integral with the casing.

Impeller :

Enclosed type dynamically balanced. Hydraulic balance is achieved either by back vanes for smaller impellers and by balancing hole with back wear rings for large impellers.

Shaft :

Three driving units cover complete range. The high tensile steel shaft accurately machined and ground is supported by anti-friction bearings. The shaft is protected by shaft sleeve from wear in stuffing box area.

Stuffing Box :

The stuffing box can be sealed by gland packing or by mechanical seal.

Bearing :

Deep groove ball bearings are provided. Standard lubrication is grease. Oil lubrication against requirement.

Direction of Rotation :

Clockwise viewed from driving end.

Drive :

Suitable for coupling with electric motors, engines directly or through belt drives.

Flanges :

Standard : Drilling as per BS EN 1092-2 (DIN 2533 ND 16)

Optional : Drilling as per IS/BS/ASA/DIN available with suitable pressure rating.



TYPICAL CROSS SECTIONAL DRAWING

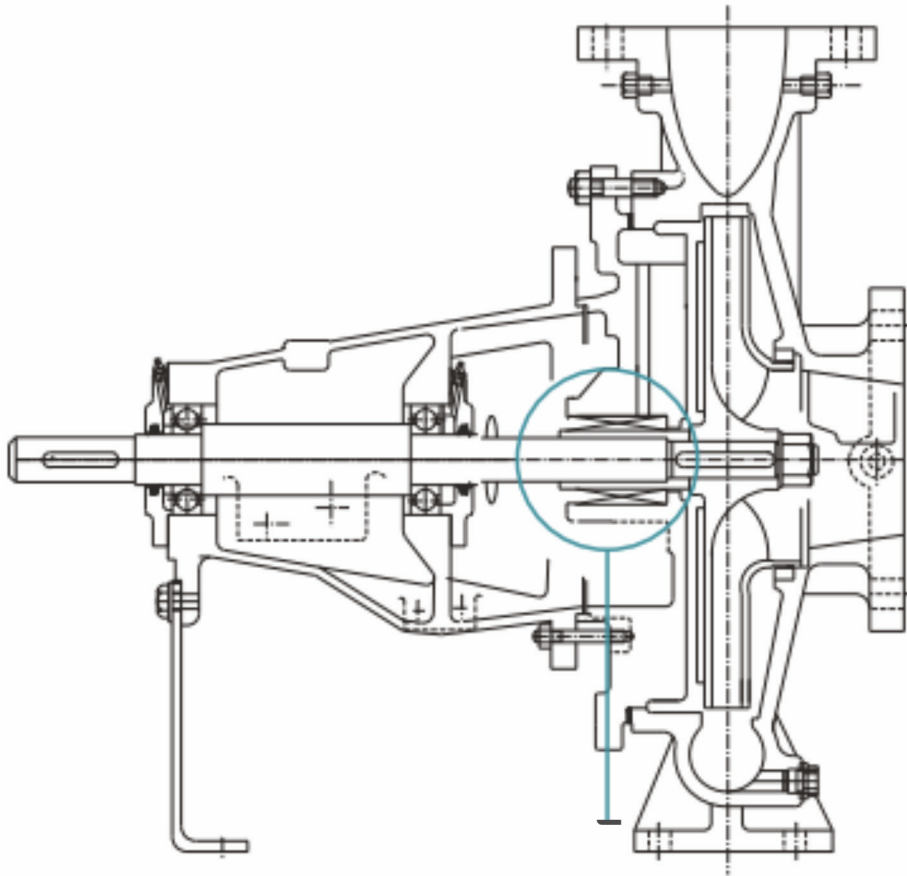

DESCRIPTION

ETANNOR Engineers provides the best range of Centrifugal Process Pumps famous with EBD – Series in a market.

Our specially designed Centrifugal Process Pump is the most preferred hydraulic pump for industrial and domestic uses. It is used to move or raise the pressure of a liquid. High-quality impeller which is used in our centrifugal pump rotates the liquid and the centrifugal force which is generated in the pump push the liquid to move out. The impeller is the device which rotates and transfer energy to the fluid.

We fabricate the centrifugal pump that includes the end-suction and back-pullout type centrifugal pump. Our heavy duty pump is capable to handle a wide spectrum of corrosive chemicals, starting from strongly oxidizing solutions to strongly reducing ones, at different temperatures and concentration, which can be used in different process plants.

MATERIAL

Casing	Cast Iron / Bronze/ Phosphor Bronze
Casing Cover	Cast Iron / Bronze/ Phosphor Bronze
Impeller	Cast Iron / Bronze/ Phosphor Bronze
Wear Ring	Cast Iron / Bronze
Shaft	Carbon Steel /Stainless Steel
Shaft Sleeve	Stainless Steel / Bronze
Lantern Ring	Nylon
Gland	Cast Iron / Bronze