



COMPONENTS

- 1 Rotating contact surface
- 2 Stationary contact surface
- 3 O-rings
- 3T PTFE wedge
- 3a O-rings
- 3Ta PTFE gasket
- 4 Springs
- 5 Metal frame
- 5a Set screws
- 5b Ring

SECTOR

- Process industry
- Oil and gas industry
- Refining technology
- Petrochemical industry
- Chemical industry
- Power plant technology
- Pulp and paper industry
- Food and beverage industry
- Hot water applications
- Light hydrocarbons
- Boiler feed pumps
- Process pumps

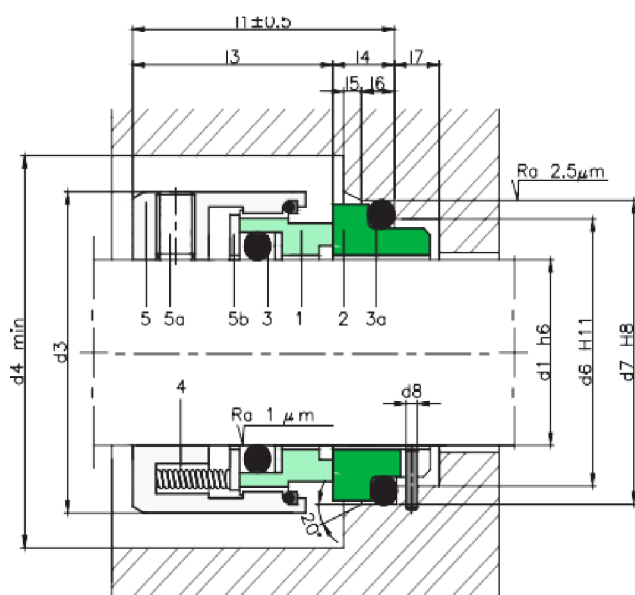

E8M

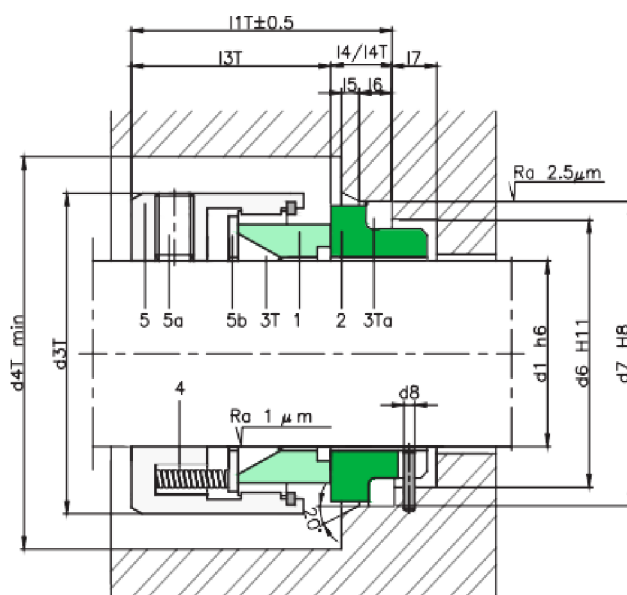

E8MT

OPERATING RANGE

$d_1 = 14 \div 100$ mm, $p = 10$ kg/cm², $v = 20$, $m/st = -15 \div +200$ °C

The temperature resistance depends on the material of the secondary seals used. The operating limits are defined by the PV factor which is determined for the sealing system characteristics and those of the application

DESCRIPTION

The balanced contact surface design allows the mechanical seal to be used in applications with high pressures without suffering premature wear.

The set of springs placed around the contact surface of the rotating part generates a more uniform load than in models with a single spring.

It can be supplied with PTFE wedge for highly aggressive chemicals with high temperatures.

Seal compliant with standard EN 12756 (KB)

SEAL FACE MATERIALS.

- Antimony impregnated carbon graphite
- Resin impregnated carbon graphite
- Sintered silicon carbide
- Reaction bonded silicon carbide
- Tungsten carbide
- Al-Oxide ceramic
- Glass filled PTFE

SECONDARY MATERIALS.

- fkm, fflkm, ptf, gft, grafoil, nbr,
- nitrile, epdm, karlez & as per customer req.

RAW MATERIALS.

- ss304, ss316, ss316l, titanium, hastalloy,
- duplex & as per customer req.

DIMENSIONS CHART**DIMENSIONS IN MM**

Shaft mm	Rotary part				Stationary part							Total length II/ IIT
	d2	d3	d4	I3	d6	d7	d8	I2 I4/ I4T	I6	I7		
ÇÇ	18	32	34	30,5	21	25	3	18	12	5,5	8,5	42,5
16	20	34	36	30,5	23	27	3	18	12	5,5	8,5	42,5
20	24	38	40	31,5		35	3	20	13,5	7	9	45
24	28	42	44	34,2	33	39	3	20	13,3	7	9	47,5
28	33	47	49	37,5	37	43	3	20	12,5	7	9	50
32	38	54	58	38	42	48	3	20	12	7	9	50
35	40	56	60	38	44	50	3	23	12	7	9	50
40	45	61	65	39,5	51	58	4	23	13	8	9	52,5
45	50	66	70	39,5	56	63	4	23	13	8	9	52,5
50	55	71	75	44	62	70	4	25	13,5	8,5	9	57,5
55	60	80	85	44	67	75	4	25	13,5	8,5	9	57,5
60	65	85	90	49	72	80	4	25	13,5	8,5	9	62,5
70	75	95	104	55,5	83	92	4	28	14,5	9,5	9	70
80	85	109	114	55	95	105	4	28	15	10	9	70
85	90	114	119	60	100	110	4	28	15	10	9	75
90	95	119	124	60	105	115	4	28	15	10	9	75
95	100	124	129	60	110	120	4	28	15	10	9	75
100	105	129	134	60	115	125	4	28	15	10	9	75

Dimensions subject to changes or modifications.

